

# EUROMAC

FORMIGINE - Italy

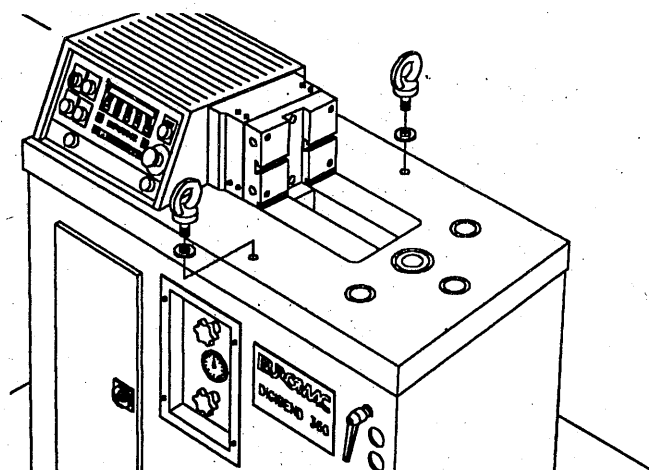

**GB** HORIZONTAL PRESSURE BENDING MACHINES WITH CNC BACK GAUGE

**D** HORIZONTALE HYDRAULISCHE DRUCKBIEGEMASCHINE MIT CNC HINTERANSCHLAG

**I** PRESSOPIEGATRICI ORIZZONTALI IDRAULICHE CON FERMAPEZZO CNC

**F** CINTREUSES HORIZONTALES HYDRAULIQUES AVEC BUTEE ARRIERE CNC

Mod.

# EUROMAC

## DIGIBEND 360

## DIGIBEND 720

2 3 6 0 1 9 8

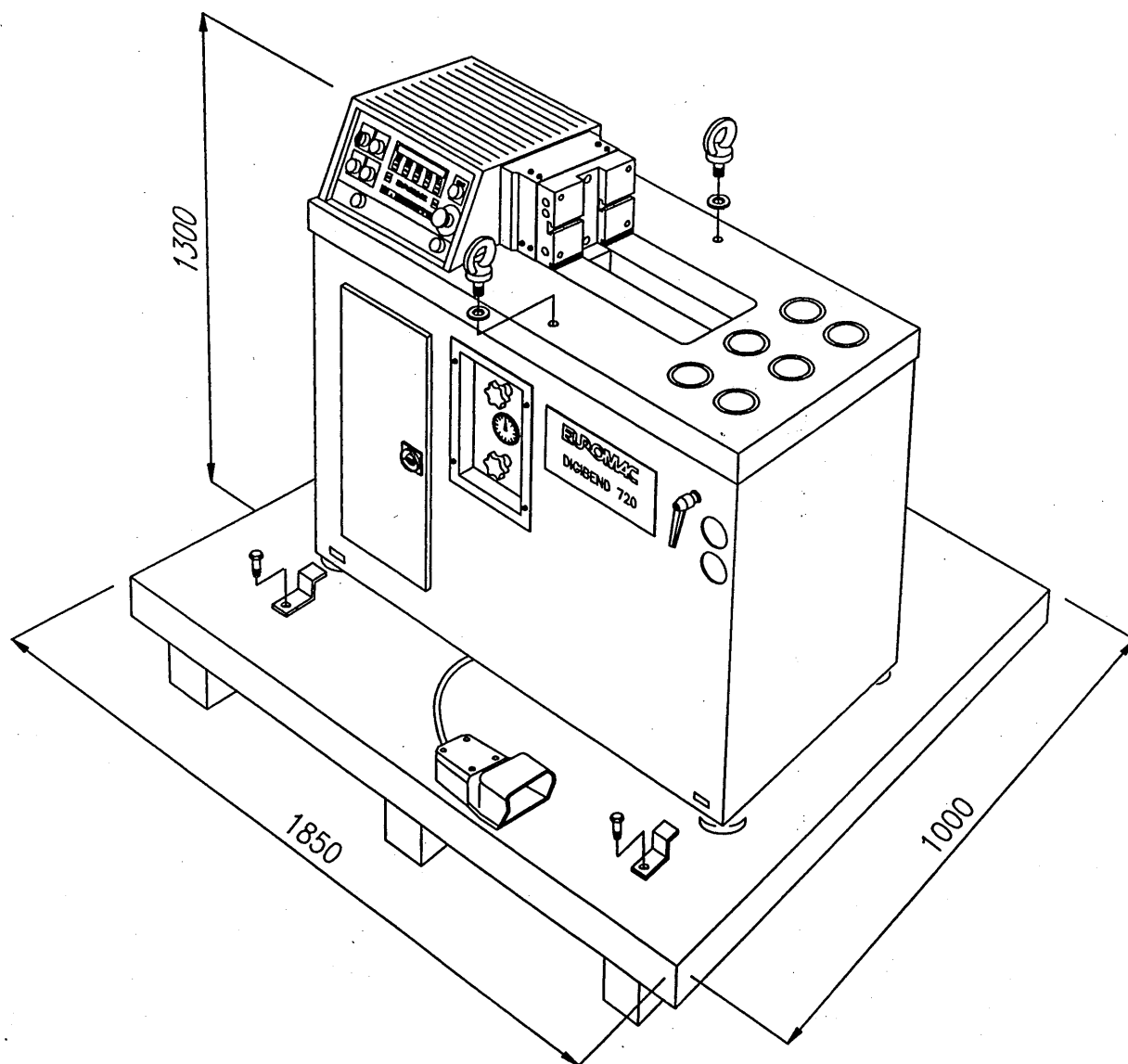

Forza lavoro	72 t	Pressione massima	Bar 260
Corsa di lavoro	350 mm	Piano di lavoro	650 x 1.520 mm.
Motore trifase	HP 5,5	Dimensioni	650 x 1.520 x 1.170 mm.
Serbatoio olio	litri 90	Peso approssimativo	1.800 kg.

<i>Working pressure</i>	<i>72 tons</i>	<i>Maximum pressure</i>	<i>Bar 260</i>
<i>Lenght of stroke</i>	<i>350 mm</i>	<i>Working surface size</i>	<i>650 x 1,520 mm.</i>
<i>3-Phase motor</i>	<i>HP 5.5</i>	<i>Dimensions</i>	<i>650 x 1,520 x 1,170 mm.</i>
<i>Oil tank capacity</i>	<i>90 litres</i>	<i>Weight (net)</i>	<i>1.800 Kg</i>

Arbeitskraft	72 t	Max. Druck	Bar 260
Hublänge	350 mm	Arbeitstisch L x B	650 x 1.520 mm
Antriebsleistung	4 Kw	Maschinenabmess.	650 x 1.520 x 1.170 mm.
Öltank	ca. 90 Ltr	Gewicht ca.	1.800 Kg.

<i>Force de travail</i>	<i>72 t</i>	<i>Pression maximum</i>	<i>Bar 260</i>
<i>Course</i>	<i>350 mm</i>	<i>Dimensions du plan de travail</i>	<i>600 x 800 mm.</i>
<i>Moteur triphasé</i>	<i>5,5 HP</i>	<i>Dimensions machine</i>	<i>1.250 x 600 x 1.100 mm.</i>
<i>Capacité du reservoir de l'huile</i>	<i>90 ltr</i>	<i>Poids approximatif</i>	<i>1.800 Kg.</i>